

筒射灯

规格书

K2E95L2

— KING 2 系列



【基本参数】

- 工艺材质: ADC12, 表面喷涂
- 电源安装: 外置
- 防护等级: IP20/IP54
- 成品色温: 2700/3000/3500/4000K/2700-6500K 可选
- 成品显指: >90
- 光源色容差: <3 Step
- 光束角: 8°/10°/15°/24°/36°/50° 可选
- UGR值: (X=4H, Y=8H): ≤1(10°/15°/24°)、≤6(36°)、≤10(50°)
- 发光方向: 向下
- 调光方式: 非调光/0-10V/可控硅/DALI 可选
- 输入电压: AC220-240V
- 工作温度: -15°C~40°C
- 产品应用: 室内
- 安装方式: 嵌入式
- 产品认证: CE、UKCA、ROHS、Reach
- 质保年限: 5 years



【外环颜色】



黑色



白色

【反射器类型】



圆孔

【反射器颜色】



哑黑



哑白



香槟金



镜面



黑铬



蜂窝网



拉伸膜

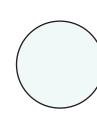

柔光膜

【光学配件】

【产品机械参数】

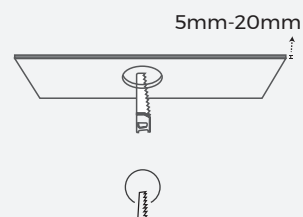
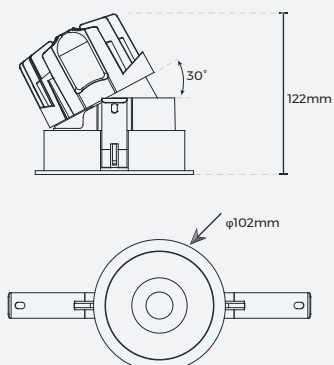
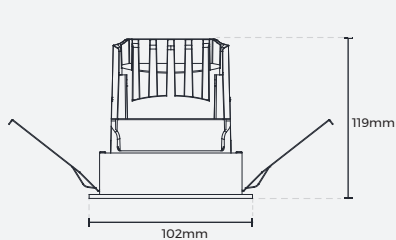

开孔尺寸: φ95mm

【灯具参数】

版本	商城型号	开孔尺寸 (mm)	LED 输入 电压(V)	LED 输入 电流(mA)	典型功率 (W)	显指	光束角	色温	流明(lm)
常规	K2E95L2	φ95	DC36	500	20	>90	10°	3000K	1120
							15°	3000K	1320
							24°	3000K	1640
							36°	3000K	1860
							50°	3000K	1780
				600	25		15°	3000K	1600
							24°	3000K	1950
							36°	3000K	2200
				750	30		50°	3000K	2125
							15°	3000K	1800
							24°	3000K	2280
							36°	3000K	2580
							50°	3000K	2520
				850	35		15°	3000K	1960
							24°	3000K	2625
36°	3000K	2940							
50°	3000K	2870							
CCT 可调	K2E95L2	φ95	DC36	500	20	>90	24°	2700K	1140
							36°		1280
							50°		1260
							24°	4000K	1360
							36°		1520
							50°		1520
							24°	6500K	1360
							36°		1500
							50°		1500

CCT 可调	K2E95L2	φ95	DC36	600	25	>90	24°	2700K	1375
							36°		1550
							50°		1525
				24°	4000K		1650		
				36°			1850		
				50°			1850		
				24°	6500K		1650		
				36°			1825		
				50°			1825		
	750	30	>90	24°	2700K	1530			
				36°		1710			
				50°		1650			
				24°	4000K	1950			
				36°		2190			
				50°		2190			
				24°	6500K	1830			
				36°		2100			
				50°		2100			
	850	35	>90	24°	2700K	1680			
				36°		1890			
				50°		1855			
24°				4000K	2240				
36°					2485				
50°					2485				
24°				6500K	2030				
36°					2310				
50°					2310				

Note:

1. 以上参数基于Ra90,3000K光源进行测试;
2700K 光效 & 光通量=3000K*0.95
3500K 光效 & 光通量=3000K*1.03
4000K 光效 & 光通量=3000K*1.05
2. 输入电压和额定电流皆为光源参数.
3. 光源品牌是科锐.
4. 驱动电源品牌是伊戈尔或艾迪明.
5. 采用以下任何一种光学配件——蜂窝网、拉伸膜或柔光膜, 都会降低光效、防眩指数以及光束角度.
6. 光通量允许有±10%的误差范围.
7. 上述参数均为典型值.

【产品配光曲线】

- 常规款

· 典型功率: 20W

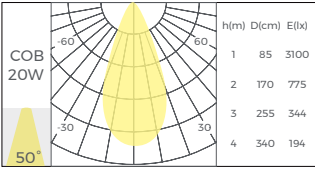
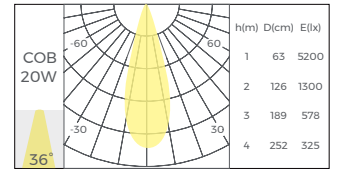
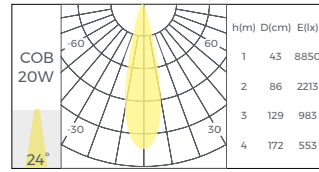
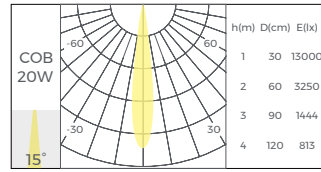
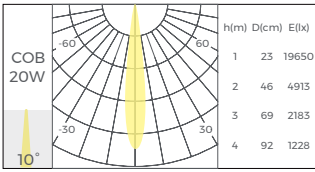

· 典型功率: 25W

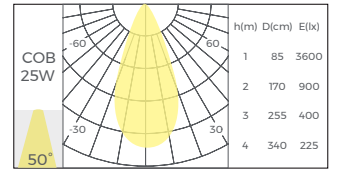
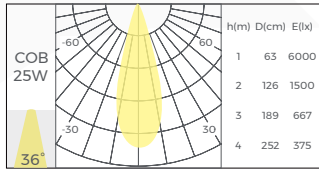
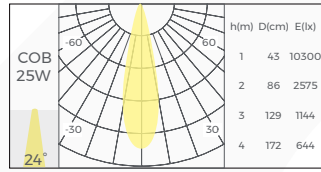
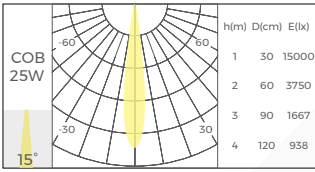

· 典型功率: 30W

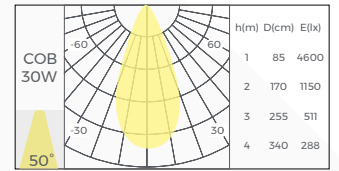
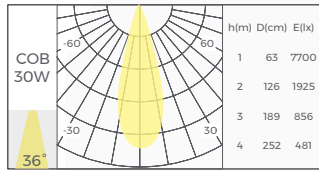
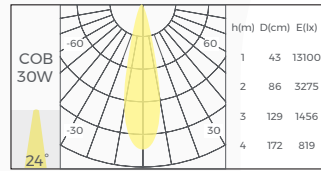
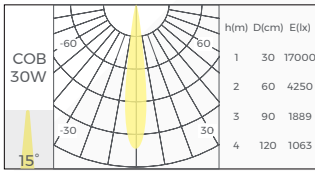

· 典型功率: 35W

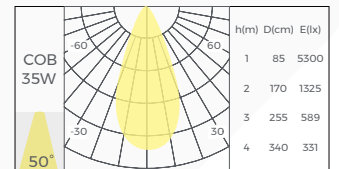
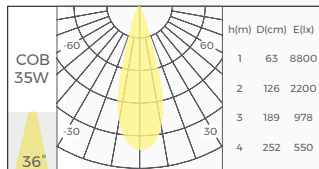
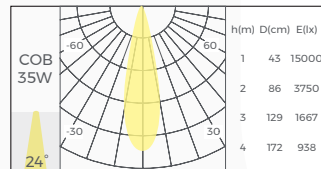
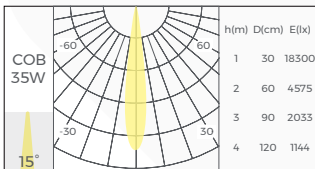

- CCT 可调

· 典型功率 :20W

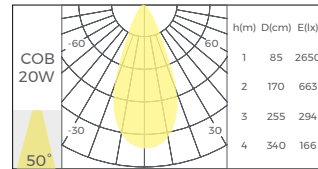
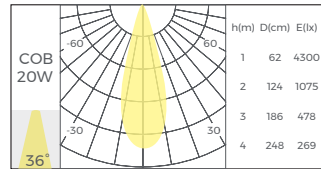
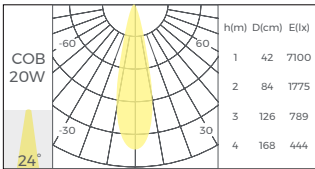

· 典型功率 :25W

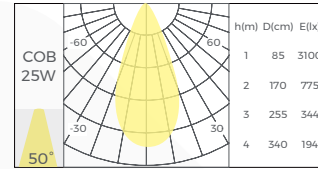
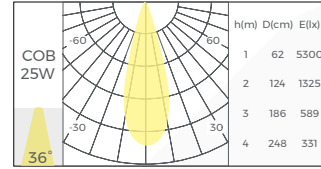
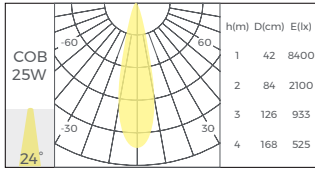

· 典型功率 :30W

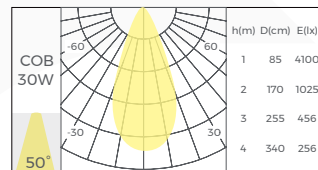
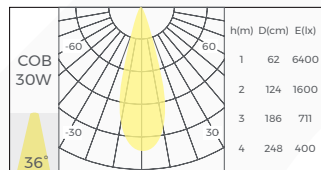
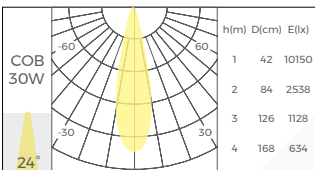

· 典型功率 :35W

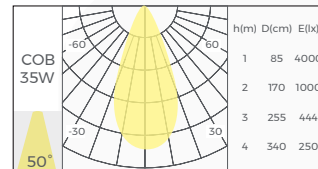
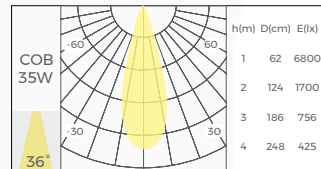
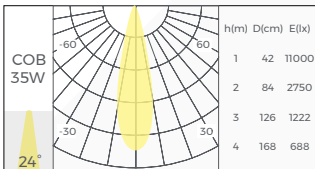

Note:

1. 中心光强值 = 1 米处的最大发光强度值;
 2. N 米最大发光光强值 = 中心光强值 / N²;
- 例如: 2 米最大发光强度值 = 中心光强值 / 2²;

【包装信息】

	内盒尺寸 (mm/盒)	产品数量 /盒	产品 数量/箱	净重 (kg/盒)	净重 (kg/箱)	毛重 (kg)	外箱尺寸 (mm/箱)
DL-K2E95L2-XXX	166*126*150	1	20	0.84	16.8	20.3	643*345*315

【注意事项】

- 1、非专业人员,禁止对产品进行安装、拆卸和维修;灯具用于照明,并根据电力法律法规和安装说明进行安装/拆除.
- 2、在安装过程中请避免对产品进行刮花、扭曲以及不规则的弯曲,否则有可能给产品造成无法修复的损伤.
- 3、裁剪时请使用专业裁剪工具.
- 4、严禁使用任何酸性、碱性粘接剂固定产品.
- 5、本产品不能应用于户外或海边环境.